

# Data Transfer of Messages with Variable Length via TCP Protocol with S7-300

FB103 "AG\_RECV\_TCP\_xVAR"

FAQ • July 2011



## Service & Support

Answers for industry.

**SIEMENS**

This entry is from the Service&Support portal of Siemens AG, Sector Industry, Industry Automation and Drive Technologies. The general terms of use ([http://www.siemens.com/terms\\_of\\_use](http://www.siemens.com/terms_of_use)) apply.

Clicking the link below directly displays the download page of this document.

<http://support.automation.siemens.com/WW/view/en/51101016>

## Question

How do you transfer data consisting of messages with variable length via TCP protocol and how do you receive the messages with variable length in the S7-300 via the Industrial Ethernet CP?

## Answer

The instructions and notes listed in this document provide a detailed answer to this question.

# Table of Contents

## Contents

<b>1</b>	<b>Introduction.....</b>	<b>4</b>
<b>2</b>	<b>Description of the Sample Program .....</b>	<b>5</b>
2.1	OB100 .....	5
2.2	OB1 .....	6
2.3	FB100.....	7
2.3.1	FC5 "AG_SEND" .....	7
2.3.2	FB103 "AG_RECV_TCP_xVAR" .....	10
2.4	Configuration of a TCP Connection .....	12
2.4.1	Determining the Number for the TCP Connection .....	13
2.4.2	Determining the Module Start Address of the Industrial Ethernet CP.....	14

# 1 Introduction

Data transmission via the TCP protocol takes the form of a data stream. There is no information transferred either about the length or about the start and end of a message.

The send data from the send application is transferred as a transparent data stream by the TCP protocol to the recipient.

The recipient application must evaluate the data stream in order to identify the start and end of a message in the data stream.

The sender defines a data structure which can be interpreted by the recipient. The data structure comprises the user data, in this example ASCII characters, and a final control character, such as (carriage return). The final control character signals the end of a message.

The Figure 1-1 shows how the send data which can be interpreted by the recipient is structured.

Figure 1-1

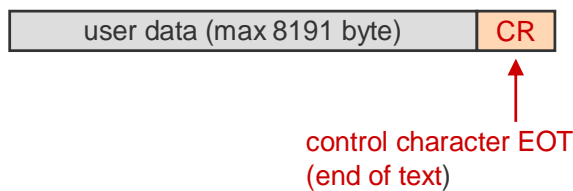

## 2 Description of the Sample Program

Data of variable message length can be received in an S7-300 station via a TCP connection which is configured in NetPro.

The functions FC5 "AG\_SEND" and FC6 "AG\_RECV" are called in the S7 program of S7-300 CPU for the transmission of data.

The FC5 "AG\_SEND" is used to send data to another S7 station, to a PC station, or to a third-party system.

The FB103 "AG\_RECV\_TCP\_xVAR" function block calls the FC6 "AG\_RECV" function internally in order to receive data with variable message length via the TCP protocol in the S7-300.

Function block FB103 "AG\_RECV\_TCP\_xVAR", which is optimized for time, can receive a programmable number of bytes, exclusively containing ASCII characters, as a closed message within an OB cycle. The user can adapt the maximum number of bytes which can be received in a cycle with FC6 "AG\_RECV" for the OB1 cycle time that it requires.

In this sample program the FC5 "AG\_SEND" function and the FB103 "AG\_RECV\_TCP\_xVAR" function block are called in the S7 program of the S7-300 CPU, allowing the S7-300 to transmit and receive 100 bytes of data, including control characters.

First of all, create the hardware configuration for your S7-300 station. Configure memory byte 10 as a clock bit memory. The send request is triggered by this clock bit memory. Save and compile the hardware configuration of your S7-300 station and load it into the CPU.

The S7 program consists of the components below.

Table 2-1

Block	Description
OB100	Startup OB for restart (warm restart)
OB1	The operating system of the CPU processes OB1 cyclically. The cyclic processing of OB1 begins when the startup finishes.
FB100	The FB100 calls the FC5 "AG_SEND" function and a TCP connection function block FB103 "AG_RECV_TCP_xVAR" in order to send and receive 100 bytes of data via a TCP connection.
DB100	Instance data block of the FB100
FB103	FB103 "AG_RECV_TCP_xVAR" calls the FC6 "AG_RECV" function internally in order to receive the data via the TCP connection. The control symbol, which signals the end of a message and is evaluated in FB103, is defined via the input parameter EOT of the FB103. The maximum number of bytes which can be received in a cycle with FC6 "AG_RECV" is defined via the input parameter MAX_LOOP of FB103. The value of the input parameter MAX_LOOP is evaluated in FB103.
DB222	The received data is stored in the DB222 data block.
DB221	The sent data is stored in the DB222 data block.

### 2.1 OB100

The OB100 is a startup OB and is run when the CPU is restarted (warm start). The bit memories M1.0 and M0.1 are set in this OB in order to issue the release for the first communication trigger.

## 2.2 OB1

OB1 is called cyclically. The FB100 is called in OB1 with the instance data block DB100 and bit memory M1.0 as the INIT\_COM parameter. The bit memory M0.3 is reset in OB1 after the FB100 has been called.

Figure 2-1

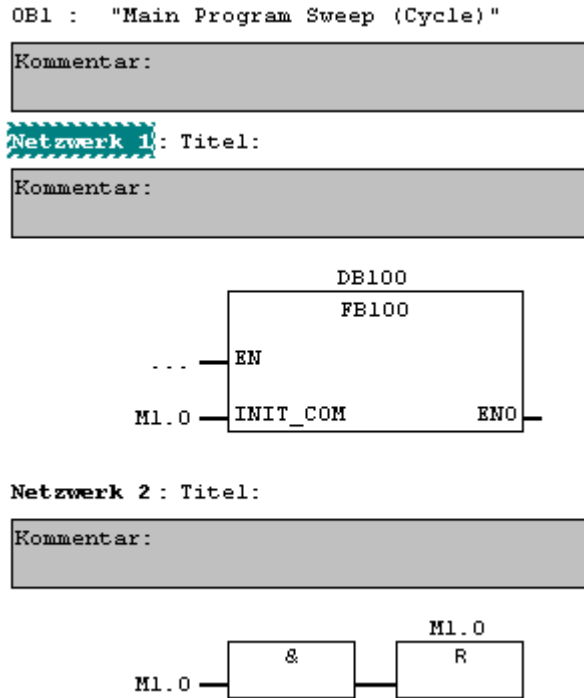

## 2.3 FB100

FB100 is called cyclically in OB1. FB100 calls the FC5 "AG-SEND" function and the FB103 "AG\_RECV\_TCP\_xVAR" function block.

### 2.3.1 FC5 "AG\_SEND"

#### Enable Send Job

Figure 2-2

**Netzwerk 2** : Start AG\_SEND function with rising edge (clock marker MB10)

Start AG\_SEND function with the rising edge of the clock marker if the AG\_SEND function is not BUSY.  
The ACT input parameter of the AG\_SEND function is triggered with a pulse and BUSY is set as long as the AG\_SEND function is not completed!

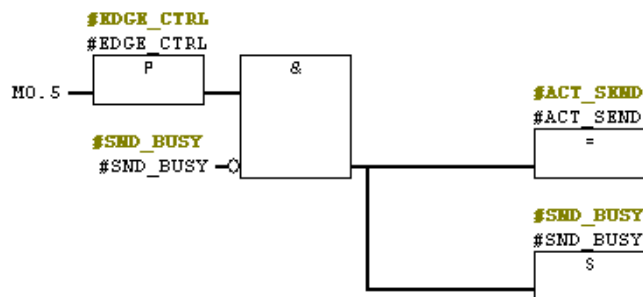

If the clock bit memory M10.5 has a positive edge and there is no send job running, the FC5 "AG\_SEND" function is enabled via the input parameter ACT, and the binary variable "SND\_BUSY" is set to value "1". No new send job can be initiated while the value of the "SND\_BUSY" variable is 1.

### Calling the FC5 "AG\_SEND" Function

Figure 2-3

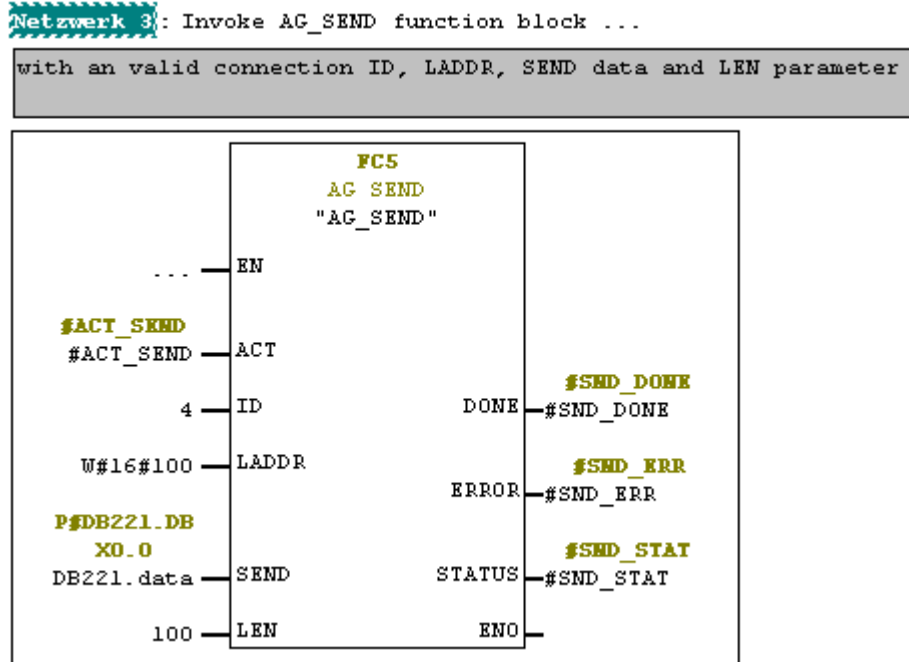

Parameterize the connection number of the TCP connection which is configured in NetPro on the input parameter ID. You can find information about determining the connection number in section 2.4.1.

Parameterize the module start address of the Industrial Ethernet CP on the input parameter LADDR. You can find information about determining the module start address of the Industrial Ethernet CP in section 2.4.2.

The input parameter SEND refers to a data area in the local CPU which contains the data to be sent. 99 bytes of user data and 1 byte control character are sent from the DB221 to the address. The control character CR=13 is used as the EOT (end of text) in this example.

Parameterize the number of bytes to be sent at the input parameter LEN.

**Notes** The number of bytes to be sent may not be greater than the reception buffer.

### Evaluation of the Send Job

The output parameters DONE, ERROR and STATUS are required for the job evaluation and are only valid in the same cycle.

Once the send job is successfully completed, the binary variable "SND\_BUSY" is reset to the value "0", to enable a new send job to be triggered.

Figure 2-4

**Netzwerk 4 : Function DONE**

If AG\_SEND has completed reset BUSY

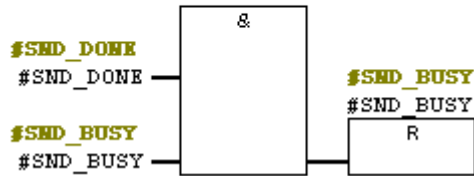

If the FC5 "AG\_SEND" is closed with an error, the value of the STATUS output parameter is saved for error analysis and the binary variable "SND\_BUSY" is reset to enable a new send job to be triggered.

Figure 2-5

**Netzwerk 5 : Evaluate STATUS**

IF function completes with ERROR then save STATUS and reset BUSY !  
Only in case of S7-400 if STATUS=0x7000 (DEZ=28672) BUSY may not be reset

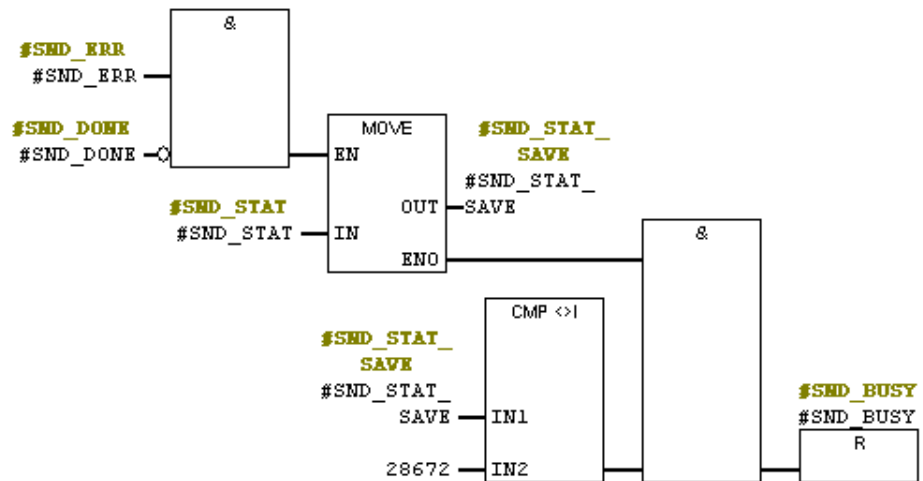

### 2.3.2 FB103 "AG\_RECV\_TCP\_xVAR"

#### Calling the FB103 "AG\_RECV\_TCP\_xVAR" Function Block

The FB103 "AG\_RECV\_TCP\_xVAR" function block enables you to receive data with variable message length via the TCP protocol in an S7-300.

Figure 2-6

Netzwerk 6 : Invoke AG\_RECV\_CR function block ...

with a valid connection ID, LADDR and RECV\_BUF

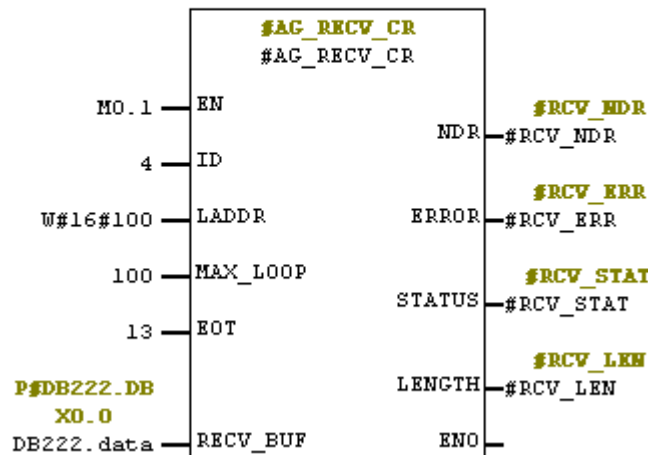

#### Input Parameters of FB103 "AG\_RECV\_TCP\_xVAR"

FB103 "AG\_RECV\_TCP\_xVAR" has the following input parameters:

Table 2-2

Input parameters	Data type	Value range	Value in the sample program
ID	INT	1 to 16 (dec)	4 (dec)
LADDR	WORD		w#16#100
MAX_LOOP	INT	1 to 8192 (dec) or up to the length specification on input parameter RECV_BUF	100 (dec)
EOT	INT		13 (dec), this means that the control character "CR" becomes EOT (End of text)
RECV_BUF	ANY		P#DB222.DBx0.0 Byte 100

#### Output Parameters of FB103 "AG\_RECV\_TCP\_xVAR"

FB103 "AG\_RECV\_TCP\_xVAR" has the following output parameters:

Table 2-3

Input parameters	Data type	Value range
NDR	BOOL	The parameter indicates whether new data has been received. 0: - 1: New data received
ERROR	BOOL	Error display 0: - 1: Error during data reception
STATUS	WORD	Status display (only valid with ERROR=1)
LENGTH	INT	Number of bytes received in the data range which is parameterized at input parameter RECV_BUF. (only valid with NDR=1)

**ID**

Parameterize the connection number of the TCP connection which is configured in NetPro on the input parameter ID. You can find information about determining the connection number in section 2.4.1.

**LADDR**

Parameterize the module start address of the Industrial Ethernet CP on the input parameter LADDR. You can find information about determining the module start address of the Industrial Ethernet CP in section 2.4.2.

**MAX\_LOOP**

The maximum number of bytes (ASCII characters) which can be received in a cycle with FC6 "AG\_RECV" is parameterized at the input parameter MAX\_LOOP. The value of the input parameter MAX\_LOOP is evaluated in the FB103 function block.

If the receive buffer of the Industrial Ethernet CP contains fewer bytes than the number which is parameterized at the input parameter MAX\_LOOP, the function block is closed immediately.

**EOT**

At the input parameter EOT (End of text) parameterize the control character which signals the end of a message, for example ETX=3, LF=10, CR=13; this is evaluated in FB103.

If the control character is detected before the end of the length which is parameterized on the input parameter MAX\_LOOP, the function block FB103 is closed with NDR=1 and specifying the length in the output parameter LENGTH.

**RECV\_BUF**

At input parameter RECV\_BUF, parameterize the data range in which the user data is saved with the length which is parameterized on input parameter MAX\_LOOP, including the control character EOT.

### Evaluation of the Receive Job

The output parameters NDR, ERROR and STATUS are required for the job evaluation and are only valid in the same cycle.

If FB103 "AG\_RECV\_TCP\_xVAR" is closed with an error, the value of the output parameter STATUS is saved for error analysis.

Figure 2-7

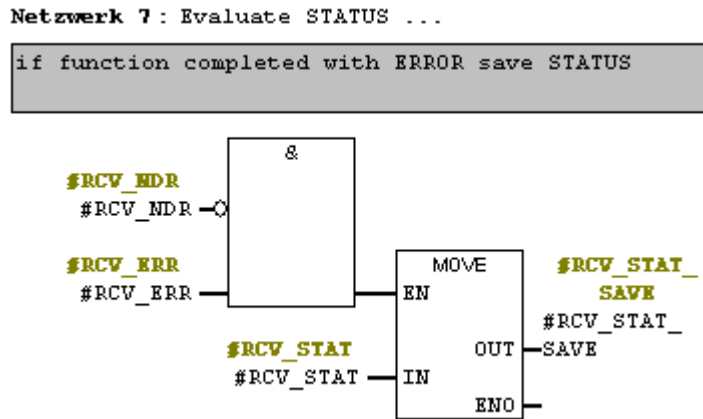

Once the receive order has been successfully completed, the length of the received data is then saved.

Figure 2-8

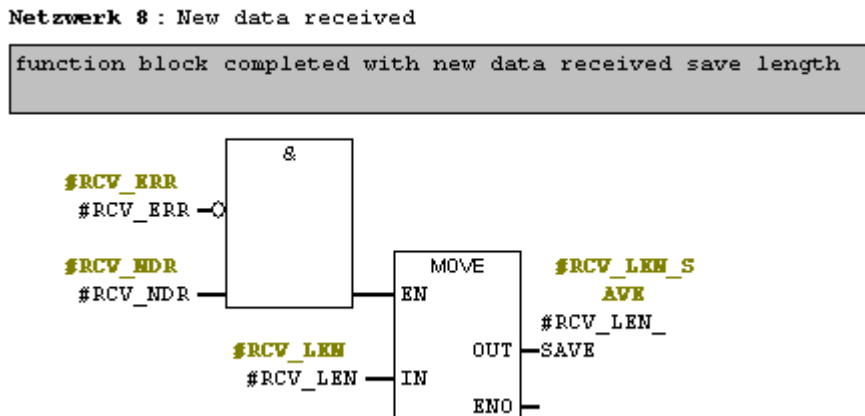

## 2.4 Configuration of a TCP Connection

The following link will take you to instructions on how to configure a TCP connection for the S7-300, enabling you to transfer data via an Industrial Ethernet CP.

<http://support.automation.siemens.com/WW/view/en/22385024>

### 2.4.1 Determining the Number for the TCP Connection

Double-click the configured TCP connection in NetPro in order to open the Properties dialog. Switch to the "General" tab in order to determine the connection number. Parameterize the connection number at the input parameter ID of function FC5 "AG\_SEND" and of function block FB103 "AG\_RECV\_TCP\_xVAR".

Figure 2-9

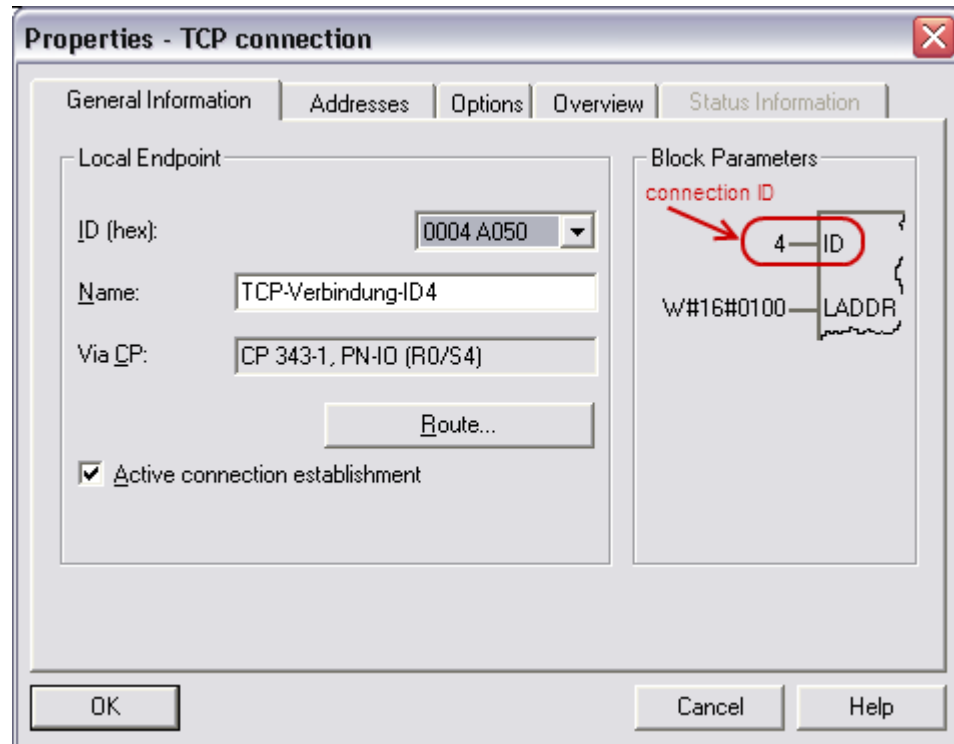

### 2.4.2 Determining the Module Start Address of the Industrial Ethernet CP

In the Hardware Configuration, you double-click the configured CP343-1 to open the Properties dialog. Switch to the "Addresses" tab in order to determine the module start address. Parameterize the module start address at the input parameter LADDR of the FC5 "AG\_SEND" function and of the FB103 "AG\_RECV\_TCP\_xVAR" function block.

Figure 2-10

